

Efficiency & Solar



System owner Ron Nichols throws the switch the first time, sending solar electricity to the utility grid.

Pay Off

Lori Hauser & Ron Nichols

©2005 Lori Hauser & Ron Nichols

By virtue of a long-held intrigue with solar energy, along with a conservationist attitude fostered by parents of the Great Depression, our attraction to renewable energy (RE) as a lifestyle felt like a natural fit. Personal choices include reducing our dependence on cars by walking, using public transportation, and riding bicycles as much as possible. We grow some of our food in an organic vegetable garden. These and other savings associated with our conservationist and energy efficient lifestyle made our financial investment in renewables a realistic and viable option.

Finding Phantoms & Improving Efficiency

Our active participation in RE began about three years ago when we invested in green electricity from Puget Sound Energy (PSE), the local utility. PSE allows its customers to choose renewable energy sources for their electricity by paying a small, additional cost per KWH. The US\$3 to \$4 more per month was worth it to know that all of the energy we were using was generated by renewable sources.

Then, through a class offered by the community college from locals who live off grid, we learned about general solar-electric system design and feasibility, along with principles of conservation. Attending the SolWest Fair in John Day, Oregon, exponentially expanded our interest in RE.

But we were limited by our budget, so before thinking about how to invest and what system to install, we studied our energy use habits to find out how we could reduce our electricity consumption.

Our home was built in the '90s and has double-pane windows. We recently upgraded to a 96 percent efficiency,

Evacuated-tube solar hot water collectors maximize heat gain on overcast days that are common in the Pacific Northwest.



gas, forced-air furnace. We added insulation to the attic and to the crawl space under the house to reduce heat loss in winter and limit heat gain in summer. We diligently began pulling shades and blinds on the windows to preserve heat on cold winter nights and to prevent overheating on hot summer days.

We used a Kill A Watt watt-hour meter to measure the energy use of all our appliances and began to eliminate phantom loads—hidden loads from devices that continue to use energy even when you've turned them "off" or are not using them. We shut off the furnace at the electrical panel in summer to eliminate its phantom load, and use a multiplug switch for the TV, VCR, and DVD player. We replaced incandescent lightbulbs with compact fluorescents, which produce the same amount of light but only use about 30 percent of the energy.

Solar Hot Water System

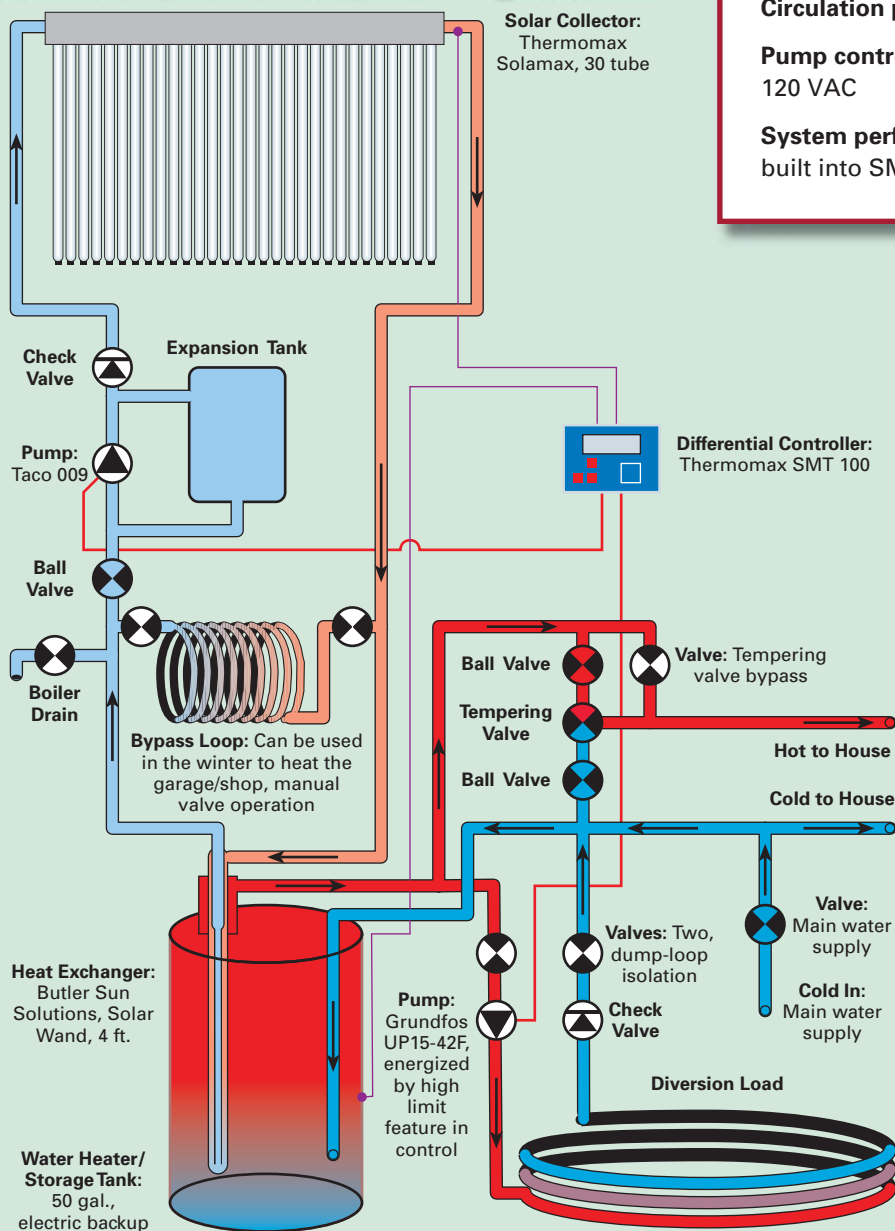

SDHW System Tech Specs

Type: Evacuated tube, pressurized glycol

Location: Mount Vernon, Washington

Production: 99 percent, April–Sept.; 50 percent or more, Oct.–Mar.

Collector: Thermomax Solamax, 30-tube collector; 48 square feet

Collector installation: Wall-mounted at 62-degree tilt

Storage: Existing 50 gal. electric hot water tank

Heat exchanger: Butler Sun Solutions Solar Wand, 4 ft.

Circulation pump: Taco 009 solar loop

Pump controller: Thermomax SMT100 controller, 120 VAC

System performance metering: Thermometer built into SMT 100 controller (tank temp.)

Fortunately, we had made energy-wise choices in selecting a front-loading washer and electric dryer from Creda, and had the added benefit of a small and efficient electric oven and a gas countertop stove. We installed a clothesline or "solar dryer," and began to plan our clothes washing according to favorable days for outdoor drying.

We discovered that our electric water heater was the largest consumer of electricity. Although we would have liked to install an on-demand (tankless) gas water heater, our situation did not lend itself well to the outdoor venting that is required. Instead, we placed a timer on the existing water heater to coordinate hot water use for morning and evening, and insulated the tank and pipes to reduce heat loss. We also installed low-flow showerheads to reduce the amount of hot water used.



A little insulation and conservation is all it took for Lori and Ron to substantially reduce their energy use. Now, the renewable energy system that fit their budget also meets their needs.

Conservation Becomes Participation

Our conservation paid off. With these simple strategies, we reduced our energy consumption by an average of 30 percent. We were excited about the way we were consuming energy thoughtfully, but without any hardship on our lifestyle. We now had a pretty good handle on what we would need for renewable energy production.

Ron attended a local hands-on workshop, and got to participate in installing a small, residential solar-electric system. Together, we visited several solar-electric and wind-powered systems throughout the Northwest as part of the American Solar Energy Society's National Solar Tour. It was now time to make the leap toward our own renewable energy production. We wanted to invest in a system that would be effective and efficient for our specific needs and situation. The savings associated with our lifestyle, and the knowledge of our energy needs, made the financial investment in solar energy and the goal of energy independence a genuine possibility.

We had saved for probably six or seven years, knowing we would be adding improvements to our home along

Solar Hot Water Production

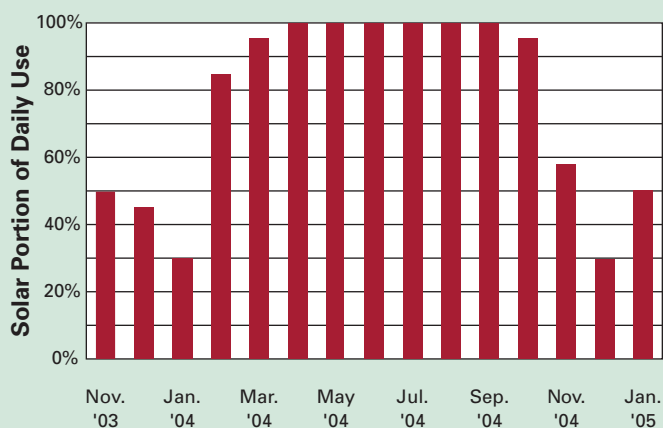

the way. But our home was relatively new and other than cosmetic choices, we had already done the necessary structural improvements. Rather than change décor or aesthetic atmosphere, buy new cars, or spend money on other consumer garbage, we chose to invest in solar energy for the future.

Solar Thermal Start

We decided to start with a solar thermal system, one of the most cost-effective uses of solar energy, to heat our water. Ron chose an evacuated tube system that performs well in the cold and overcast conditions common here in the Pacific Northwest.

Solar Hot Water System Costs

Item	Cost (US\$)
30 Solamax tubes	\$1,428
AST 30 solar manifold	628
Taco pump set, with expansion tank & plumbing	532
Labor	500
Solar Wand heat exchanger	275
Thermomax differential controller	267
Mount for collector & manifold	165
Misc. pipe, fittings, insulation	159
Misc. plumbing, valves, drain	112
Shipping	100
Kitec tubing & misc.	100
Grundfos UP15-42F circulating pump	88
Propylene glycol antifreeze, 1 gal.	16
C-H breaker, 20 A	6
Total	\$4,376

Many Hands

Lori and Ron turned the installation of their photovoltaic system into an educational experience for others in their community. Through a Solar Energy International (SEI) workshop, two dozen enthusiastic students got hands-on experience installing a renewable energy system. See Access for info on how you can participate in a similar event.

Left: Laying out the mounting rack.

Right: Ron Nichols and an SEI student install the first PV panel.



Right: MC connectors make series wiring easy.

Below: Bolting down the PV array.



Left: Everyone helps.

Below: Testing PV array voltage.



Below Left: Lori and students watch the meter spin backwards.

Below: Success!



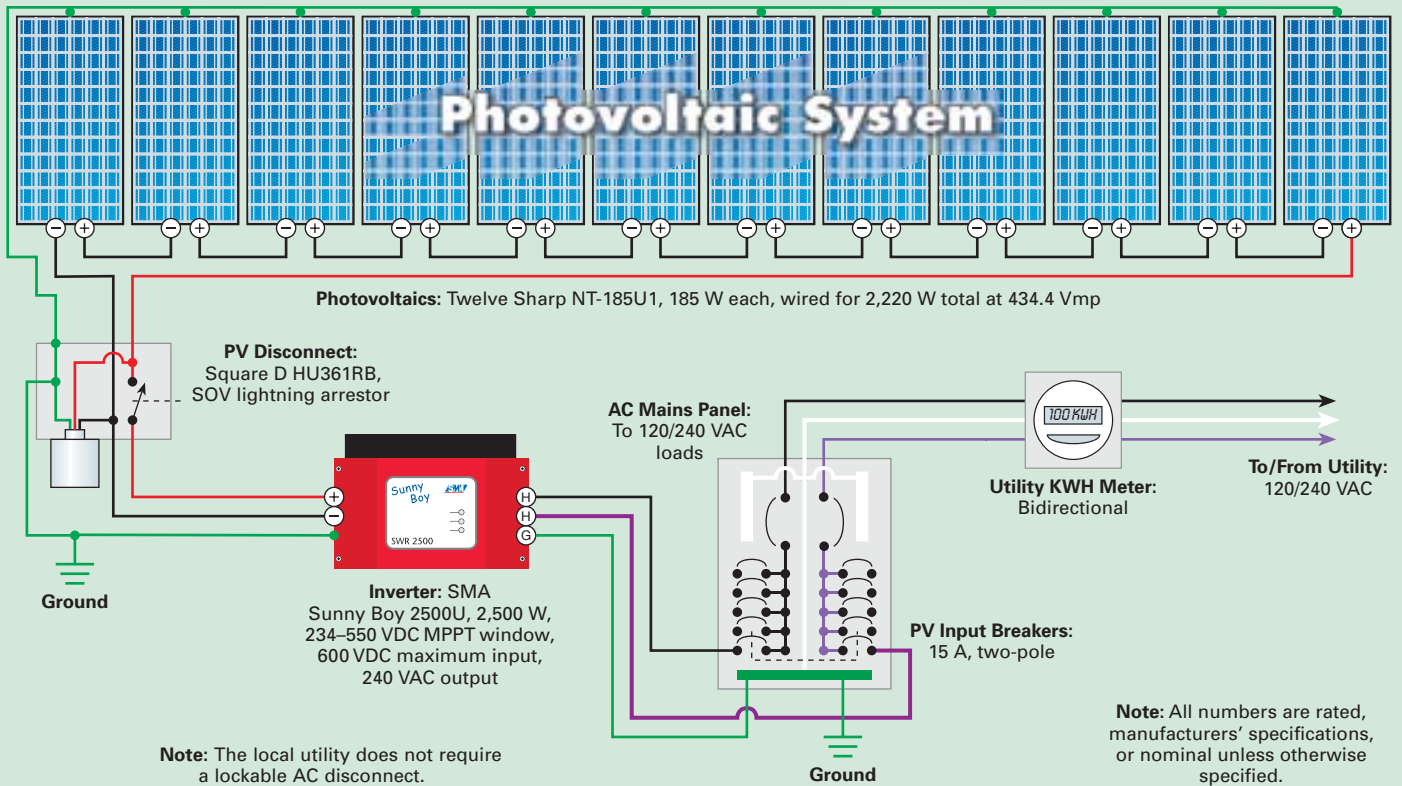

PV System Tech Specs

Type: Batteryless, grid-tie PV

Solar resource: 3.5 average daily peak sun hours

Production: 160 AC KWH per month average

Utility electricity offset: 100 percent

Photovoltaics

PV: Twelve Sharp NT-185U1, 185 W STC, 36.2 Vmp, 24 VDC nominal

Array: One, 12-module series string, 2,220 W STC, 434.4 Vmp

Array disconnect: Square D HU361RB

Array installation: UniRac SolarMount, 23-degree tilt

Balance of System

Inverter: SMA Sunny Boy 2500U, 2,500 W, 600 VDC maximum input, 234–550 VDC MPPT voltage window, 240 VAC output

System performance metering: Bidirectional AC KWH meter and Sunny Boy inverter display

Our Solamax 30-tube system is mounted on the south side of the house at a 62-degree angle—an optimal orientation that takes advantage of the sun's lower path in the sky during wintertime. In summer, we knew the system would be producing more hot water than we use, so we did not need to maximize summer exposure.

The existing electric water heater serves as the storage tank. A 4-foot-long (1.22 m) Solar Wand submerged in the hot side of the tank serves as a heat exchanger and uses propylene glycol to transfer heat. Given the high heat capacity of the glycol running through the tubes, there needed to be a way to accommodate overproduction during peak periods. We routed this "dump load" through Kitec PEX tubing—engineered composite pipe made from flexible aluminum and cross-linked polyethylene tubing—in the crawl space under the house.

Since its installation in November 2003, the system has impressed us. Between April 2004 and September 2004, it met almost 100 percent of our hot water needs, which average about 20 gallons per person, per day. During the fall and winter months, it meets about 50 percent of our demand.

Next Steps

Given the freedom from depending on electricity to heat our water, our electrical consumption was diminished to a manageable level (a monthly average consumption of 185 KWH) that could be met with a modest PV system. Through our good fortune, we had the opportunity to become a workshop site for Solar Energy International (SEI). With the

PV System Production vs. Consumption

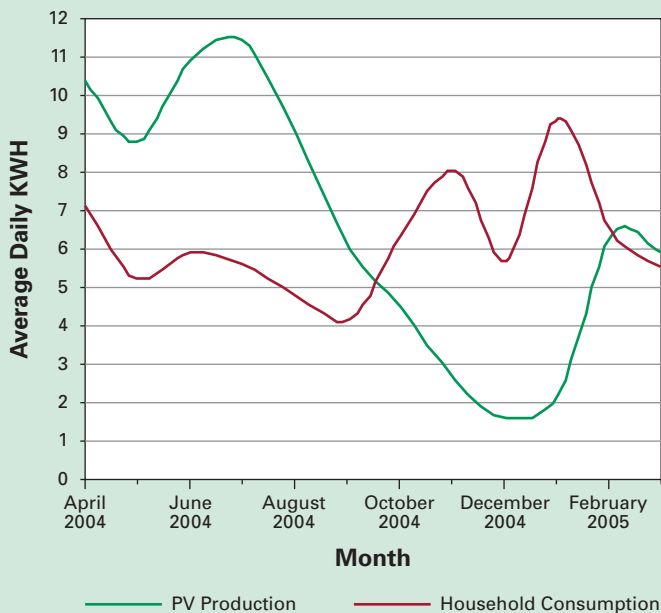

help of SEI participants and instructors, we installed twelve Sharp 185 W monocrystalline modules on the south side of our roof, and tied the array to a Sunny Boy 2500 inverter. This project was the first grid-tied PV system in our town.

Because we have no batteries to baby-sit, the system is simple to use and maintain. Since April 10, 2004, when the installation was completed, the PV system has produced an average of 6.59 KWH per day. We've only used an average of 6.2 KWH a day. PSE allows us to "bank" excess energy we produce on an annual, rather than a monthly basis. This enables us to accumulate a surplus of stored kilowatt-hours during sunny months to help offset our electrical usage during cloudy months, when system production is lower.

PV System Costs

Item	Cost (US\$)
12 Sharp NT-185UI PV modules	\$9,528
SMA 2500U inverter, with display	2,950
UniRac module mounts	1,054
Shipping	319
Square D HU361RB DC disconnect	181
Misc. conduit & electrical	125
Scissor lift rental, 1 day	112
2 Multiconductor cables, 100 ft.	100
Electrical building permit	76
Delta lightning arrestor	42
C-H BR215 two-pole breaker, 15 A	9
Total	\$14,496

Investing in the Future

There are many avenues to take in pursuing renewable energy, and we can all make a difference. One simple yet powerful way to invest in renewable energy is to buy green power from your local utility. Supply follows demand, and demand from enthusiastic, educated, and informed people will make a difference.

Investing in renewable energy is our way of investing in the future. Anything we do to reduce our dependence on nonrenewable energy sources is positive, no matter how small it may be to start—it goes beyond our own pocketbooks and into the preservation of the world's resources.

Access

Lori Hauser & Ronald Nichols, 524 Jefferson St., Mt. Vernon, WA 98274 • 360-336-1085 • lhauser@mv.k12.wa.us

Jeffrey Utter, Alternative Energy Solutions, 3231 Hillside Rd., Deming, WA 98244 • 360-303-5024 • Fax: 360-592-5166 • SDHW installation assistance

Butler Sun Solutions, PO Box 1666, Solana Beach, CA 92075 • Phone/Fax: 858-259-8895 •

butlersunsolutions@adelphia.net • www.butlersunsolutions.com • Solar Wand in-tank heat exchangers & parts for solar-assisted hot water systems

Creda • www.creda.com • Horizontal-axis clothes washer, efficient electric clothes dryers (imported from the UK)

Delta Lightning Arrestors, PO Box 750, Big Spring, TX 79721 • 800-335-8252 or 432-267-1000 • Fax: 800-335-8227 • deltala@msn.com • www.deltala.com

Ipex Inc., 9940 E. 47th St., Denver, CO 80238 • 800-473-9808 or 303-754-0102 • Fax: 303-754-0109 • www.ipexinc.com • Kitec PEX tubing

P3 International, 132 Nassau St., New York, NY 10038 • 888-895-6282 or 212-346-7979 • Fax: 212-346-9499 • info@p3international.com • www.p3international.com • Kill A Watt meter

Jay Peltz, Peltz Power, PO Box 2391, Redway, CA 95560 • 707-923-3477 • jay@asis.com • SEI workshop instructor & PV system supplier

Sharp Electronics Corp., 5901 Bolsa Ave., Huntington Beach, CA 92647 • 800-SOLAR-06 or 714-903-4600 • Fax: 714-903-4858 • sharpsolar@sharpsec.com • www.solar.sharppusa.com • PV panels

SMA America Inc., 12438 Loma Rica Dr., Grass Valley, CA 95945 • 530-273-4895 • Fax: 530-274-7271 • info@sma-america.com • www.sma-america.com • Sunny Boy inverter

Solar Energy International, PO Box 715, Carbondale, CO 81623 • 970-963-8855 • Fax: 970-963-8866 • sei@solarenergy.org • www.solarenergy.org • RE workshops

Taco Inc., 1160 Cranston St., Cranston, RI 02920 • 401-942-8000 • 401-942-2360 • marcha@taco-hvac.com • www.taco-hvac.com • SDHW circulating pumps

Thermomax Industries Ltd., 3181 Kingsley St., Victoria, BC,
Canada V8P 4J5 • 888-923-9443 or 250-721-4360 •
Fax: 888-923-9443 or 250-721-4329 •
zev@solarthermal.com • www.solarthermal.com •
Solamax evacuated tube collectors & controllers

UniRac Inc., 3201 University Blvd. SE, Ste. 110,
Albuquerque, NM 87106 • 505-242-6411 •
Fax: 505-242-6412 • info@unirac.com • www.unirac.com •
Rack mounting system

